



FAM CHS-2D



- ▶ Capacity up to 5,500 pounds per hour.
- ▶ Simple design with hinged in-feed chute and cover for easy cleaning and maintenance.
- ▶ 7.5 hp variable speed motor.
- ▶ Product path is completely separated from the drive parts.
- ▶ Stainless steel gear box requiring no lubrication reduces maintenance costs and down-time significantly.
- ▶ Inexpensive, quick-release & disposable knives.
- ▶ Accepts cutting heads from other brands.

**TYPE OF CUTS:**

Produces precise cuts in sizes ranging from 1/32" to 3/16" including: crescent, oval, flake, full shred and "v" cut.



oval (cheddar)



flake (parmesan)



full shred (cheddar)



v-cut (swiss)

# CHS-2D TECHNICAL SPECIFICATIONS

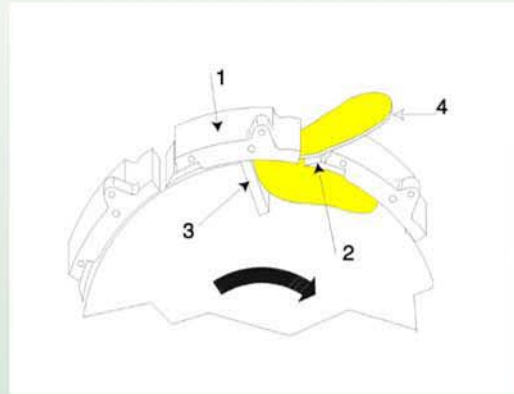

- 1. Cutting head
- 2. Knife
- 3. Impeller wheel
- 4 Product

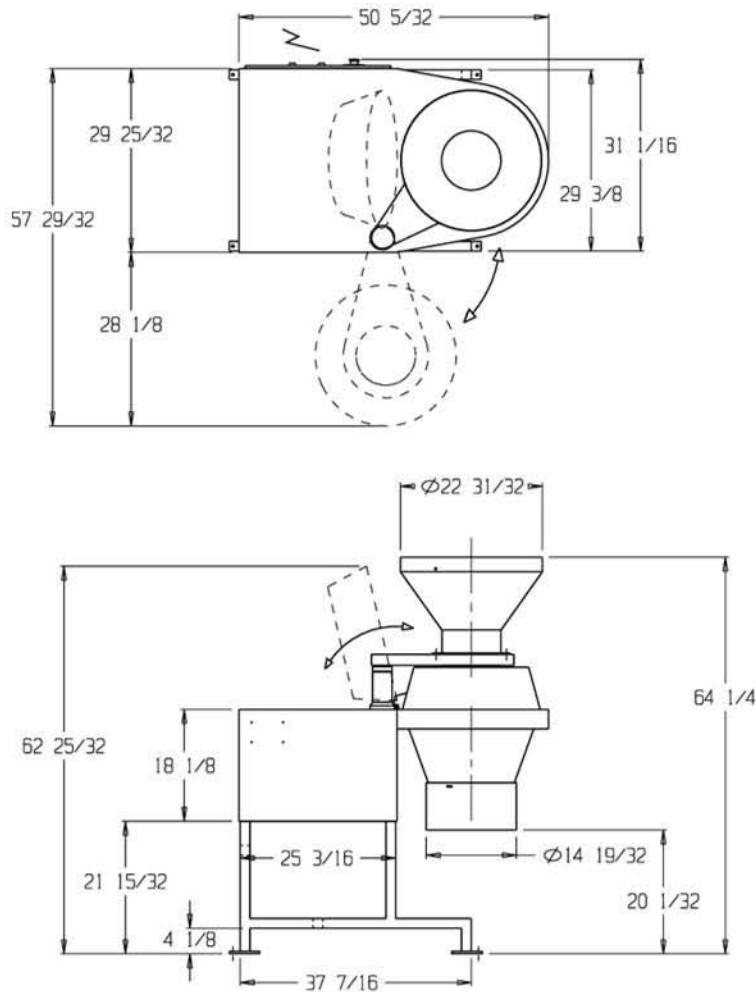

Length: 1275mm (50,20")  
 Width: 790mm (31,10")  
 Height: 1590mm (62,60")

Net weight: 300kg (660lbs)  
 Motor: 5,5kW (7.5HP)  
 Capacity: 2500kg/hour (5500 lbs/hour)